

Servomotors

with brushless drive

EC 60



Features

- Electronically commutated 3-phase servomotor
- Brushless drive
- High output performance concurrently with compact build
- Incremental measuring system
- Hall sensors
- IP44 protection class
- Uses: Positioning controllers, speed control
- Connection via circular plug
- Option: Brake

General

Brushless EC motors are designed as electronically switched 3-phase synchronous motors. Compared with brush drives, these motors have an even longer working life, because they are subjected to less wear. Moreover, in this case, high power density and dynamic response relative to size must be emphasized. These motors are used in many automation technology areas and in CNC machines.

Technical specification

Part no.	Description	Rated output W	Rated voltage V DC	Current A	Number of poles	Rated speed rpm.	Torque at rated speed Nm	Peak torque Nm	Length L (mm)	Weight kg
474156 0048	EC 60S	156	48	6.9	8	3,000	0.5	1.75	73	1.25
474156 1048	EC 60S with brake	156	48	6.9	8	3,000	0.5	1.75	73	2.0
474235 0048	EC 60L	235	48	10.5	8	3,000	0.75	2.25	94	1.6
474235 0310	EC 60L	235	310	1.6	8	3,000	0.75	2.25	94	1.6
474235 1310	EC 60L with brake	235	310	1.6	8	3,000	0.75	2.25	94	2.35

Dimensioned drawings

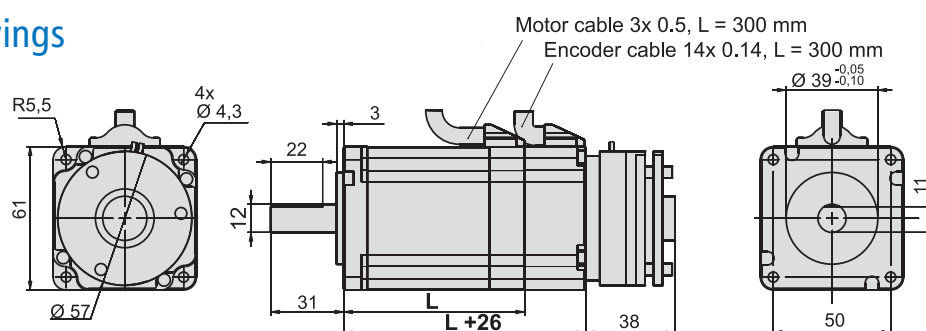

Pin assignments

Encoder cable

PIN	Colour	Signal	PIN	Colour	Signal
1	yellow	HALL_A_IN	9	white	HALL_B_IN
2	red	VCC_Encoder	10	black	GND_Encoder
3	orange/black	/ENC_Z	11	orange	ENC_Z
4	brown/black	/ENC_B	12	brown	ENC_B
5	grey/black	/ENC_A	13	grey	ENC_A
6	--	--	14	green	HALL_C_IN
7	--	--	15	--	--
8	--	--			

Motor cable

Colour	Signal
yellow	Motor U
blue	Motor V
green	Motor W

Subject to technical changes.

Servomotors

with brushless drive

EC 86



Features

- Electronically commutated 3-phase servomotor
- Brushless drive
- High output performance concurrently with compact build
- Incremental measuring system
- Hall sensors
- IP44 protection class
- Uses: Positioning controllers, speed control
- Connection via circular plug
- Option: Brake

General

Brushless EC motors are constructed as electronically switched 3-phase synchronous motors. Compared with brush drives, these motors have an even longer working life, because they are subjected to less wear. Moreover, in this case, high power density and dynamic response relative to size must be emphasized. These motors are used in many automation technology areas and in CNC machines.

Technical specification

Part no.	Description	Rated output W	Rated voltage V DC	Current A	Number of poles	Rated speed rpm.	Torque at rated speed Nm	Peak torque Nm	Length L mm	Weight kg
474440 0310	EC 86S	440	310	3.4	8	3,000	1.4	5.0	100	2.6
474660 0310	EC 86L	660	310	3.6	8	3,000	2.1	7.4	125	4

Dimensioned drawings

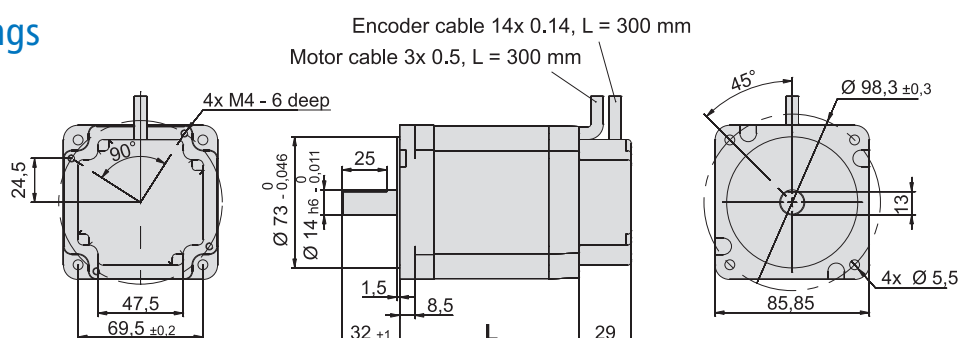

Pin assignments

Encoder cable

PIN	Colour	Signal	PIN	Colour	Signal
1	yellow	HALL_A_IN	9	white	HALL_B_IN
2	red	VCC_Encoder	10	black	GND_Encoder
3	orange/black	/ENC_Z	11	orange	ENC_Z
4	brown/black	/ENC_B	12	brown	ENC_B
5	grey/black	/ENC_A	13	grey	ENC_A
6	--	--	14	green	HALL_C_IN
7	--	--	15	--	--
8	--	--			

Motor cable

Colour	Signal
yellow	Motor U
blue	Motor V
green	Motor W

Subject to technical changes.